

## HEAD LINE/SMALL 2AH

Bestseller with versatile application possibilities

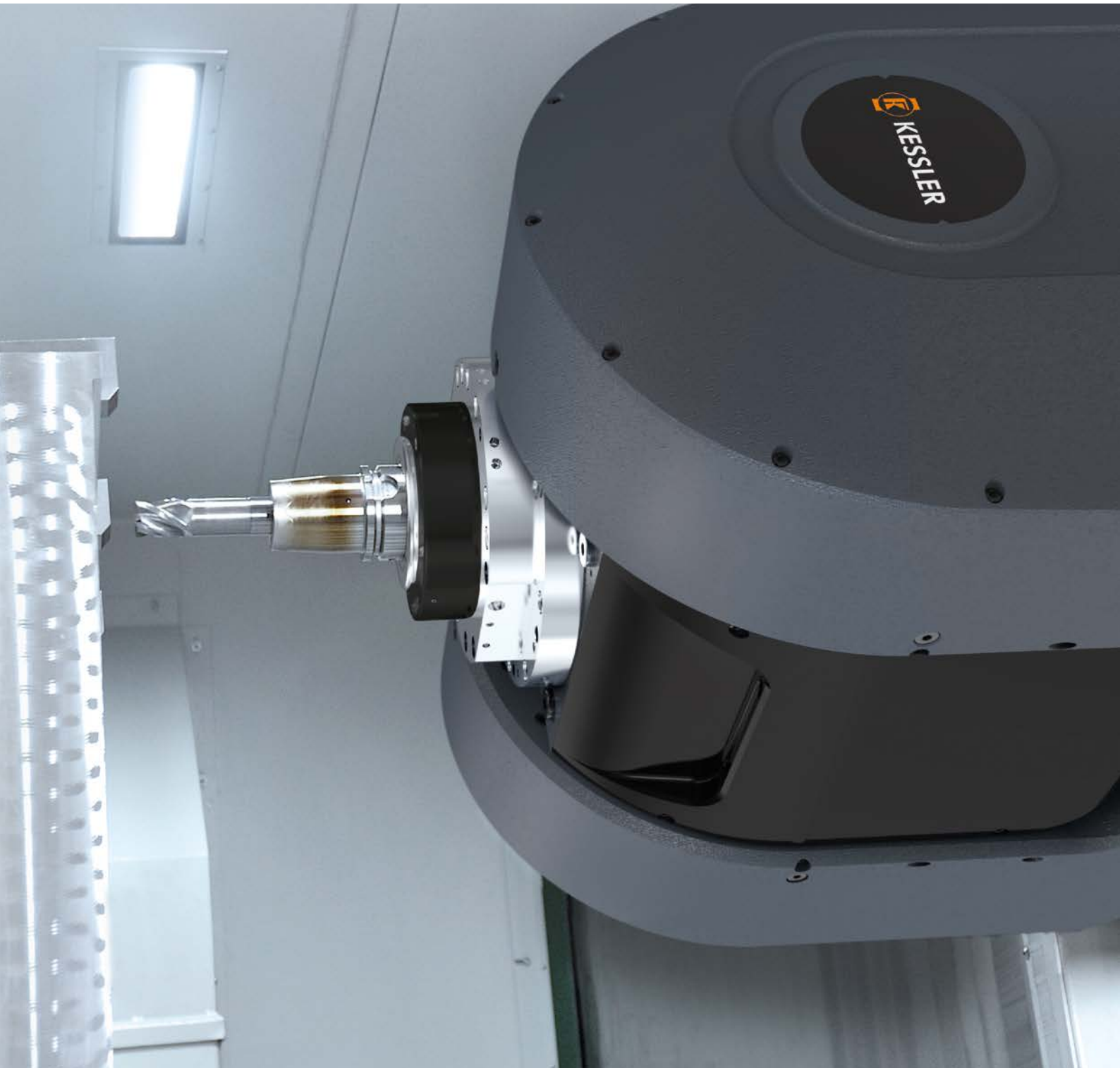

# HEAD LINE / SMALL 2AH (QAC)

**C-axis (turning axis)**

- Torque S1: 1,139 Nm
- Maximum torque: 2,277 Nm
- Clamping: hydraulic
- Clamping torque: 4,000 Nm
- Tilting angle:  $\pm 360^\circ$
- Measuring system: absolute
- Accuracy of measuring system:  $\pm 2.8''$

**A-axis (tilting axis)**

- Torque S1: 1,100 Nm
- Maximum torque: 2,200 Nm
- Clamping: hydraulic
- Clamping torque: 4,000 Nm
- Tilting angle:  $\pm 110^\circ$
- Measuring system: absolute
- Accuracy of measuring system:  $\pm 2.8''$

All 2AHs available with automatic Quick Axis Change (QAC) or as 1AH with solid screw-on flange available.

Dimensions (mm)		large fitting	small fitting
Fitting diameter of C-axis	D1	390	335
Fitting depth of C-axis	L3	715	655
Collision circle C-axis	D2	670	670
Width of A-axis	B1	625	625
Depth of A-axis	T1	420	420
Projection length of A-axis	L2	410	470
Vector length	L1	260 (HSK63) / 280 (HSK100)	
Gross weight	kg	750	750



## Options

### A-axis

- + **With one motor**  
Torque S1: 550 Nm  
Maximum torque: 1,100 Nm
- + **Pneumatic Clamping**  
with safety function  
Clamping torque: 2,160 Nm
- + **Measuring system**  
with enhanced accuracy  $\pm 2.0''$   
for use with all standard control systems
- + **Leakage monitoring**

### C-axis

- + **Pneumatic clamping**  
with safety function  
Clamping torque: 3,024 Nm
- + **Measuring system**  
with enhanced accuracy  $\pm 2.0''$   
for use with all standard control systems
- + **Horizontal or vertical installation position**



## Motor spindles

Model	Max. speed (rpm)	S1		S6 / 40 %		S6 / 25 %		S6 max.		
		Torque (Nm)	Power (kW)	Torque (Nm)	Power (kW)	Torque (Nm)	Power (kW)	Torque (Nm)	Power (kW)	
MT100S-S20	20,000	85	20	100	20	115	20	170	20	<b>High speed</b>
MT100S-S12	12,500	100	36	120	40	130	43	200	48	<b>High torque</b>
MT100L-S20	20,000	130	45	160	45	180	45	200	45	<b>High speed</b>
MT100L-S12	12,500	175	54	210	54	235	54	280	54	<b>High torque</b>
MT100H-S16	16,000	160	60	180	60	210	60	240	60	<b>High speed</b>
MT100H-S12	12,500	200	54	235	54	270	54	315	54	<b>High torque</b>

# Quick Axis Change (QAC) Automatic A-axis change

QAC enables uncompromising roughing and finishing with one single machine. The head kinematics remains unchanged. Since the projection length of the A-axis (L2) is the same, no space is lost in the machining area.

C-axis with changing interface for replaceable heads

## QAC MEDIUM

- Torque S1: 2,500 Nm
- Maximum torque: 5,700 Nm
- Clamping: hydraulic
- Clamping torque: 12,500 Nm
- Tilting angle:  $\pm 360^\circ$
- Measuring system: absolute
- Accuracy of measuring system:  $\pm 2.8''$

## Options

- + **Pneumatic clamping**  
with safety function  
Clamping torque: 9,900 Nm
- + **Measuring system**  
with enhanced accuracy  $\pm 2.0''$   
for use with all standard  
control systems

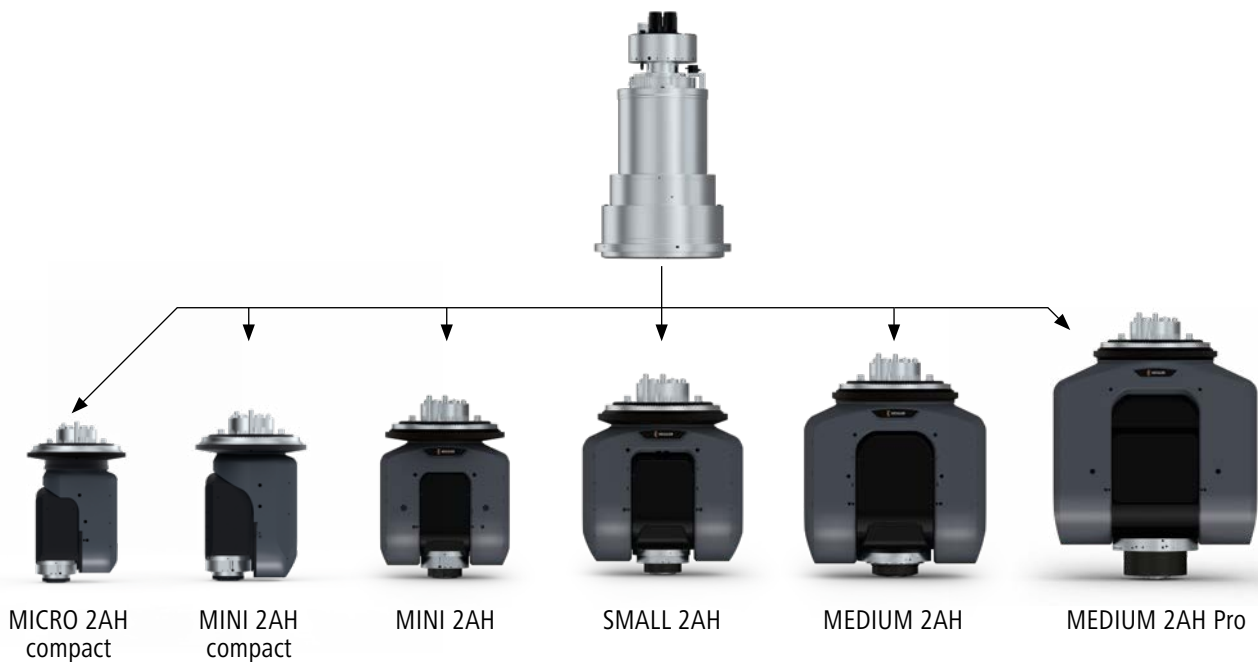

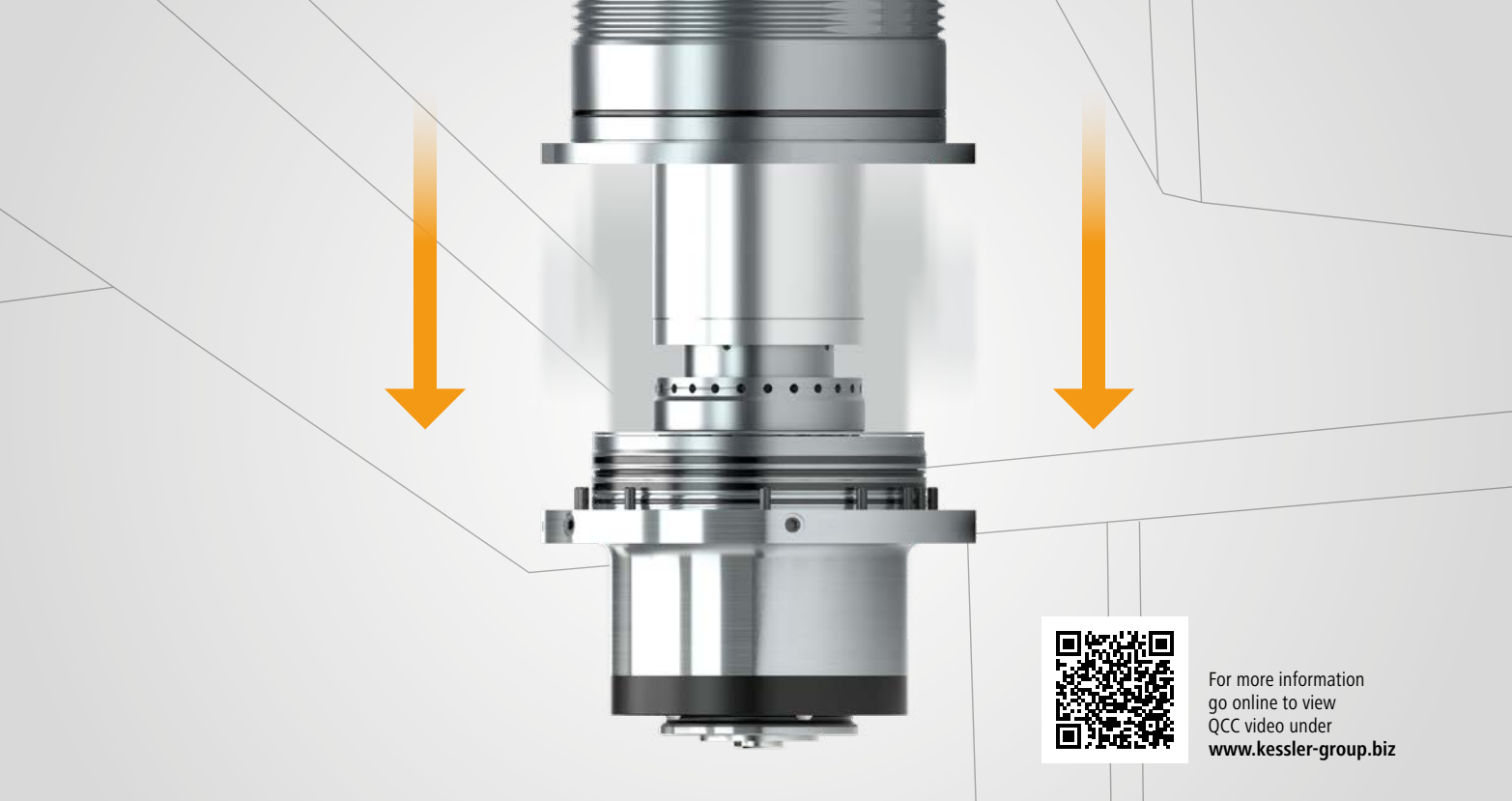

For more information  
go online to view  
QCC video under  
[www.kessler-group.biz](http://www.kessler-group.biz)

The built-in spindle housing remains in the headstock of the machine during the replacement procedure

## Quick Connect Cartridge (QCC)



1. DISASSEMBLY OF THE CARTRIDGE FROM THE MOTOR SPINDLE



2. ASSEMBLY OF THE NEW CARTRIDGE



3. RESTARTING OF OPERATION



Fast replacement of rotor shaft, front/rear bearing and power drawbar on-site



Reduces TCO (Total Costs of Ownership)



Reduces machine downtime



No electrician needed

# Operating Worldwide for our Customers

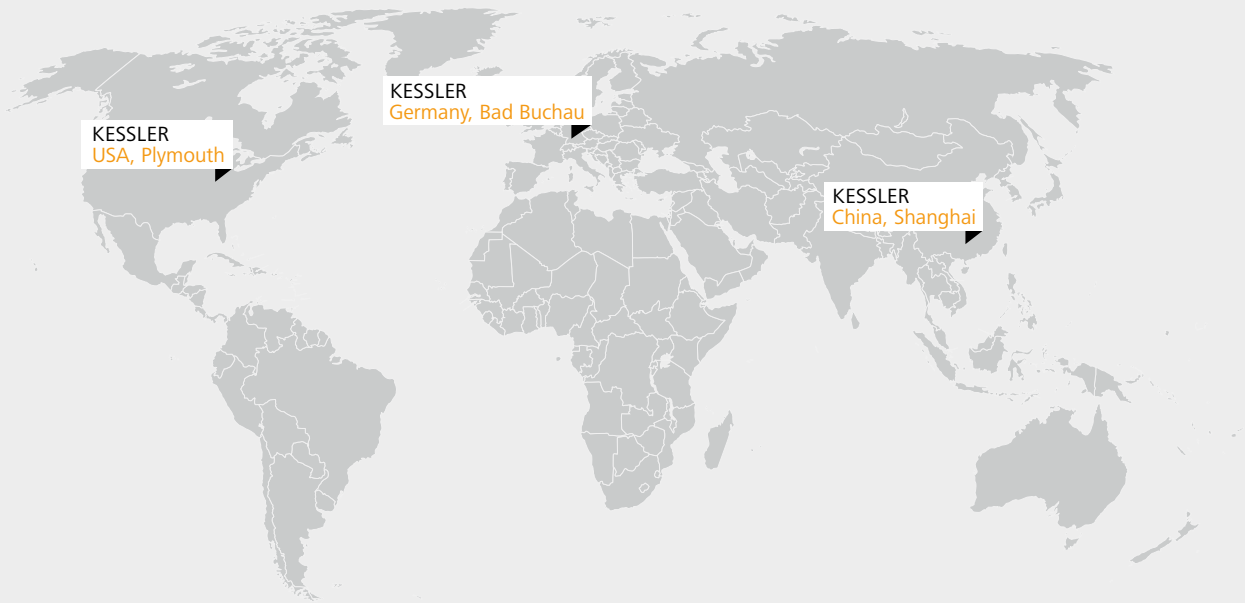

## Germany

**Franz Kessler GmbH**  
Franz-Kessler-Straße 2  
88422 Bad Buchau, Germany  
Tel.: +49 7582 809 - 0  
Fax: +49 7582 809 - 170  
info@kessler-group.biz

## USA

**KESSLER USA Inc.**  
44099 Plymouth Oaks Blvd.  
Plymouth, MI 48170, USA  
Tel.: +1 734 404 0152  
Fax: +1 734 404 0153  
info.usa@kessler-group.biz

## China

**KESSLER (Shanghai)  
Spindle Service Co., Ltd.**  
Building #12  
No.318 Yuanshan Rd  
Minhang District  
201108 Shanghai, China  
Tel.: +86 21 6489 7034  
Fax: +86 21 6489 7134  
info.cn@kessler-group.biz